



 probe lockers



 probe shelving



 probe cupboards



 probe mobile shelving



 probe library shelving



 probe cloakroom



 probe cabinets



 probe plastic lockers



Plastic Lockers

Solutions for every environment

ULTRABOX®



ULTRABOX®

STYLE, INDOORS OR OUTSIDE*

*If sheltered from direct rain



ULTRABOX PLUS⁺

PERFORMS IN THE MOST CHALLENGING ENVIRONMENTS

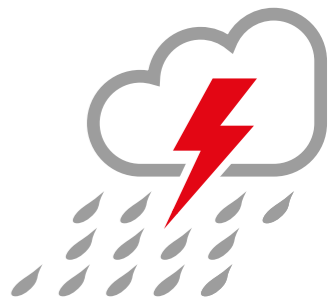

SEAL OUT THE WEATHER

WATERPROOF SEAL, PLUG AND LOCK GASKET MAKES THE ULTRABOX PLUS FULLY WATERPROOF†

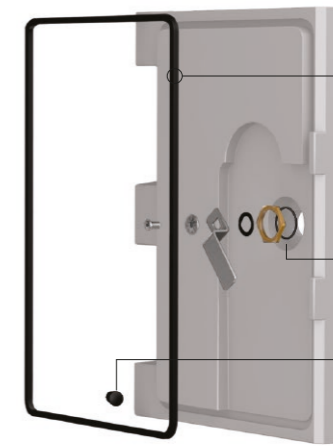

WATERPROOF DOOR SEAL

WATERPROOF LOCK GASKET

WATERPROOF DRAIN HOLE PLUG

SUITABLE FOR THE MOST CHALLENGING ENVIRONMENTS AND ALL WEATHER CONDITIONS



††Terms and conditions apply, see www.probe-manufacture.co.uk for details.

†We recommend the use of weather resistant or waterproof locks.

PROBE

www.probe-lockers.com



ULTRABOX[®]

PLASTIC LOCKERS

- ▶ CORROSION PROOF
- ▶ VANDAL RESISTANT
- ▶ HIGHLY WATER RESISTANT
- ▶ NO ON-SITE ASSEMBLY
- ▶ 10 YEAR GUARANTEE^{††}
- ▶ GRAFFITI PROOF
- ▶ NO ASSEMBLY REQUIRED



^{††}Terms and conditions apply, see www.probe-manufacture.co.uk for details.

PROBE

www.probe-lockers.com



- NO ON-SITE ASSEMBLY
- VANDAL RESISTANT
- RUST PROOF

- 10 YEAR GUARANTEE††
- WATERPROOF*
- ANTI-BACTERIAL
- ONE PIECE DESIGN
FOR A NEATER FINISH AND SPEEDY INSTALLATION

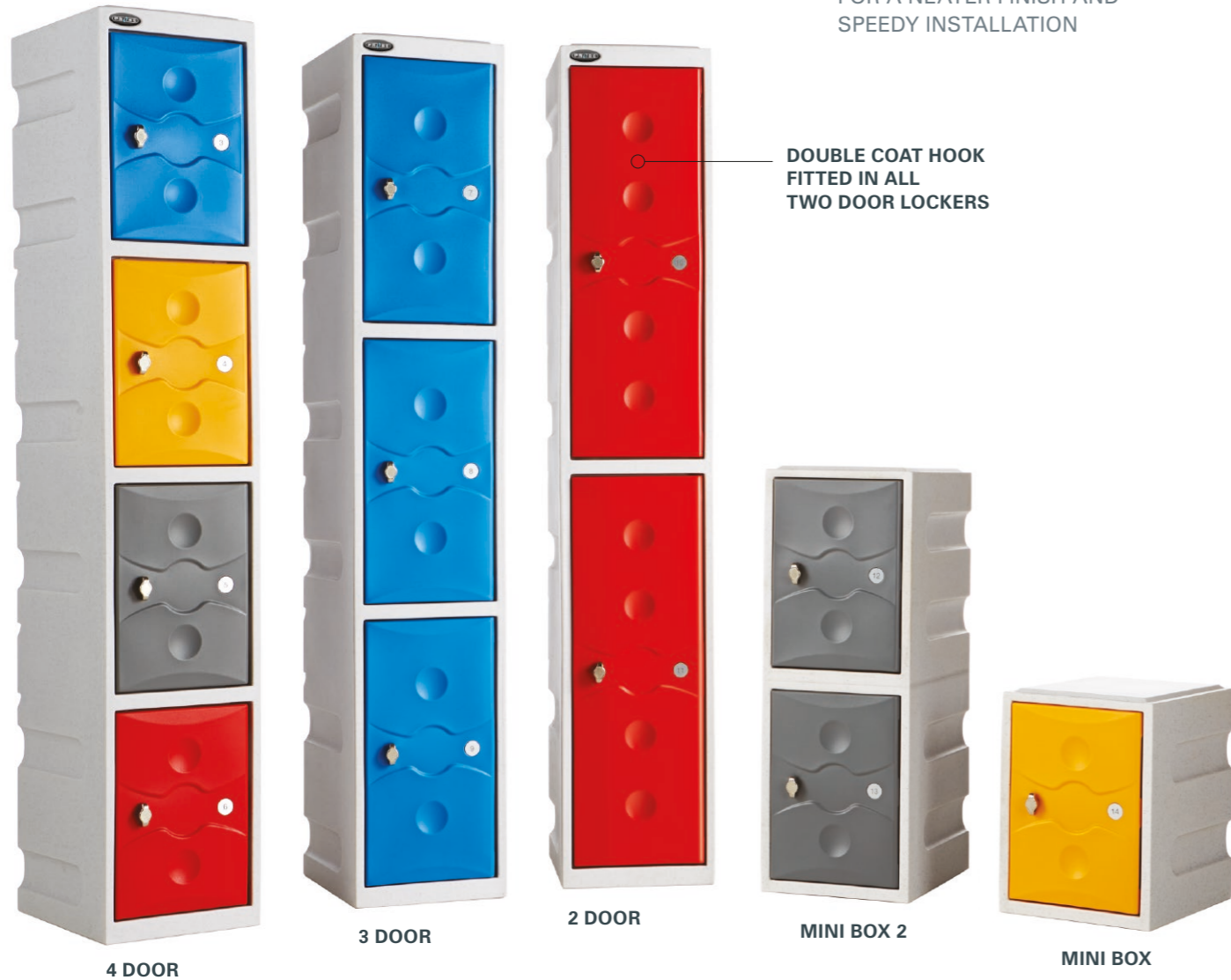

AVAILABLE COLOURS FOR ULTRABOX LOCKERS

DOOR COLOUR

RED RAL 3020	BLUE RAL 5015	YELLOW RAL 1028	GREY RAL 7031
------------------------	-------------------------	---------------------------	-------------------------

BODY COLOUR

SPECKLED GREY RAL 7047

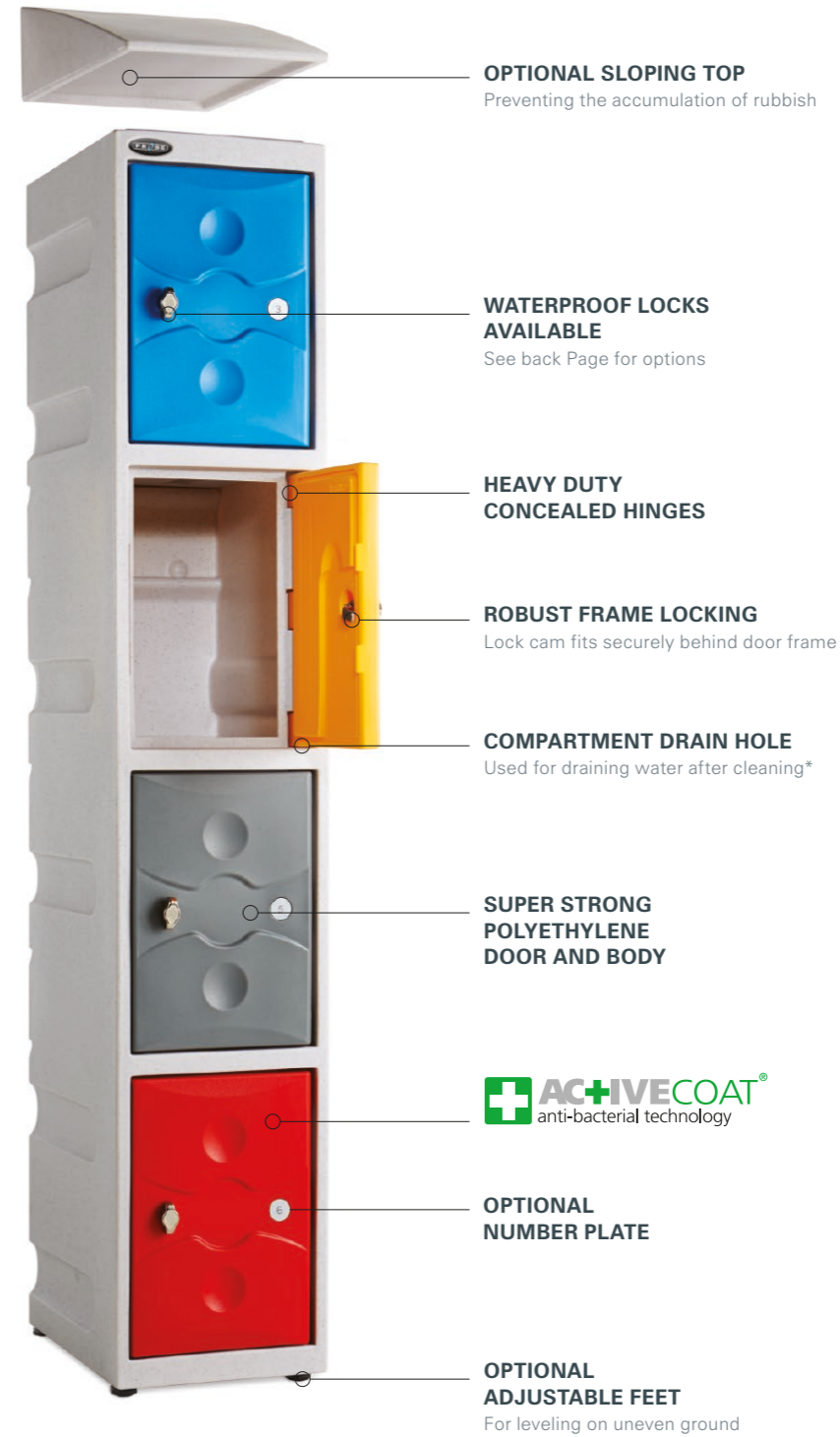

OPTIONAL WATERPROOF SEAL MAKES THE ULTRABOX PLUS FULLY WATERPROOF



HEAVY DUTY, VANDAL PROOF CONCEALED HINGES



COMPARTMENT DRAIN HOLE SITS NEATLY OUT OF SIGHT BEHIND THE DOOR*



SLOPING SHELF ALLOWS JET WASH WATER TO DRAIN TOWARDS THE DRAIN HOLE
Drain hole is sealed on Ultrabox plus

††Terms and conditions apply, see www.probe-manufacture.co.uk for details.

*The drain hole is sealed on the Ultrabox Plus version.



ULTRABOX®

STYLE, INDOORS OR OUT*

*If sheltered from direct rain



ULTRABOX PLUS⁺

PERFORMS IN THE MOST CHALLENGING ENVIRONMENTS

SUITABLE FOR EXTREME ENVIRONMENTS AND ALL WEATHER CONDITIONS

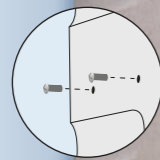
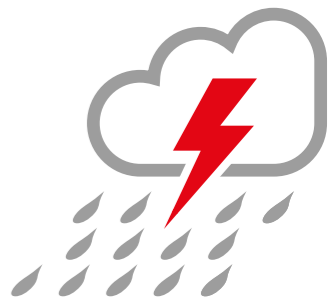

NESTING

Pre formed markers allow for easy drilling and bolting when nesting is required. Rubber gasket ensures a secure and water proof connection between lockers.

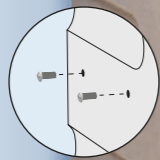
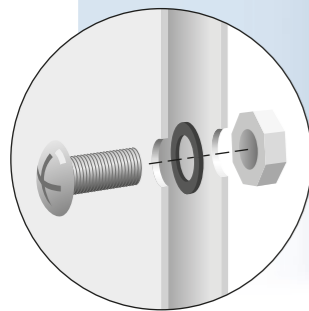

A RANGE OF LOCKS SHOWN HERE FOR ILLUSTRATION PURPOSES SEE BACK PAGE FOR FULL RANGE



††Terms and conditions apply, see www.probe-manufacture.co.uk for details.

†We recommend the use of weather resistant or waterproof locks

PROBE

www.probe-lockers.com



FULLY WATERPROOF

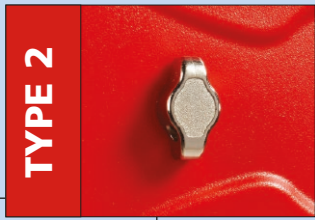

Included in 'Ultrabox Plus' locker price.
Request lock type at time of ordering.

WATERPROOF HASP & STAPLE

This design allows easy padlock fitting. Shank diameter min 5mm - max 7mm. Padlock sold separately.

- WATERPROOF

WATERPROOF CAM LOCK

This is a Waterproof Chlorine resistant high quality 7 pin tumbler system with a nickel silver key. Its all brass construction lends itself for use in harsh environments such as swimming pools. Two keys are included with each standard lock.

- WATERPROOF
- CHLORINE RESISTANT



DIGITAL COMBINATION LOCK 40,000 COMBINATIONS

- WATERPROOF
- CHLORINE RESISTANT
- Simple to program
- Batteries last up to 50,000 operations
- Single user supplied as standard
- Multi user option available (specify when ordering)

THE RFID KEYLESS DIGITAL COMBINATION LOCK

This lock provides contact less RFID locking and can be used independently or paired with existing wireless systems. Simple to upgrade existing installations and compatible with most wireless standards including RFID and NFC, the lock comes with a wide range of accessories and options.

CAN BE USED HORIZONTALLY
Subject to minimum order quantity.
Specify when ordering.

WATERPROOF COIN/TOKEN - RETURN/RETAIN

These Waterproof and Chlorine resistant locks are available with coin denominations £/€ or tokens, for either return or retain.

- WATERPROOF
- CHLORINE RESISTANT

NEW RE-PROGRAMMABLE COMBINATION LOCK

User Re-programmable
An effective 4 digit code combination lock with 10,000 possible combinations, making losing keys a thing of the past. Suitable for multi user applications. Master override key sold separately.

WEATHER RESISTANT

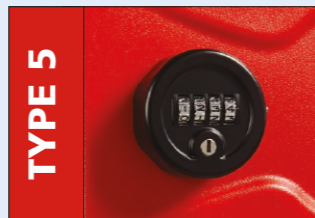
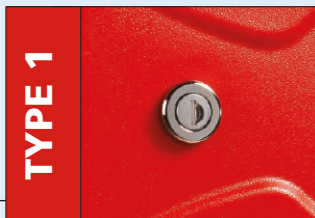

WATER RESISTANT CAM LOCK

Micro sprung 10 disc lock incorporating spring loaded weather shield. This lock features a massive 3000 serial combinations all exclusive to Probe.

Two keys are included with each standard lock.



- WEATHER RESISTANT

RE-ENGINEERED RE-PROGRAMMABLE COMBINATION LOCK

Reprogrammable Combination Lock, tough Zinc Alloy housing and dials with 10,000 possible combinations. Lost codes reset with key, sold separately. Suitable for multi user applications.

- WEATHER RESISTANT

NO WEATHER PROTECTION



RE-PROGRAMMABLE COMBINATION LOCK

Re-programming using service key
Easy to use front facing dial with 10,000 combinations. One Service Key required per installation, Service Key sold separately. Not recommended for multi user applications.

DIGITAL COMBINATION LOCK 40,000 COMBINATIONS

- Simple to program
- Batteries last up to 50,000 operations
- Single user supplied as standard
- Multi user option available (specify when ordering)
- Emergency access using service key

'DRY VERSION' COIN/TOKEN - RETURN/RETAIN

Available with coin denominations £/€ or tokens, for either return or retain (coin return pictured).

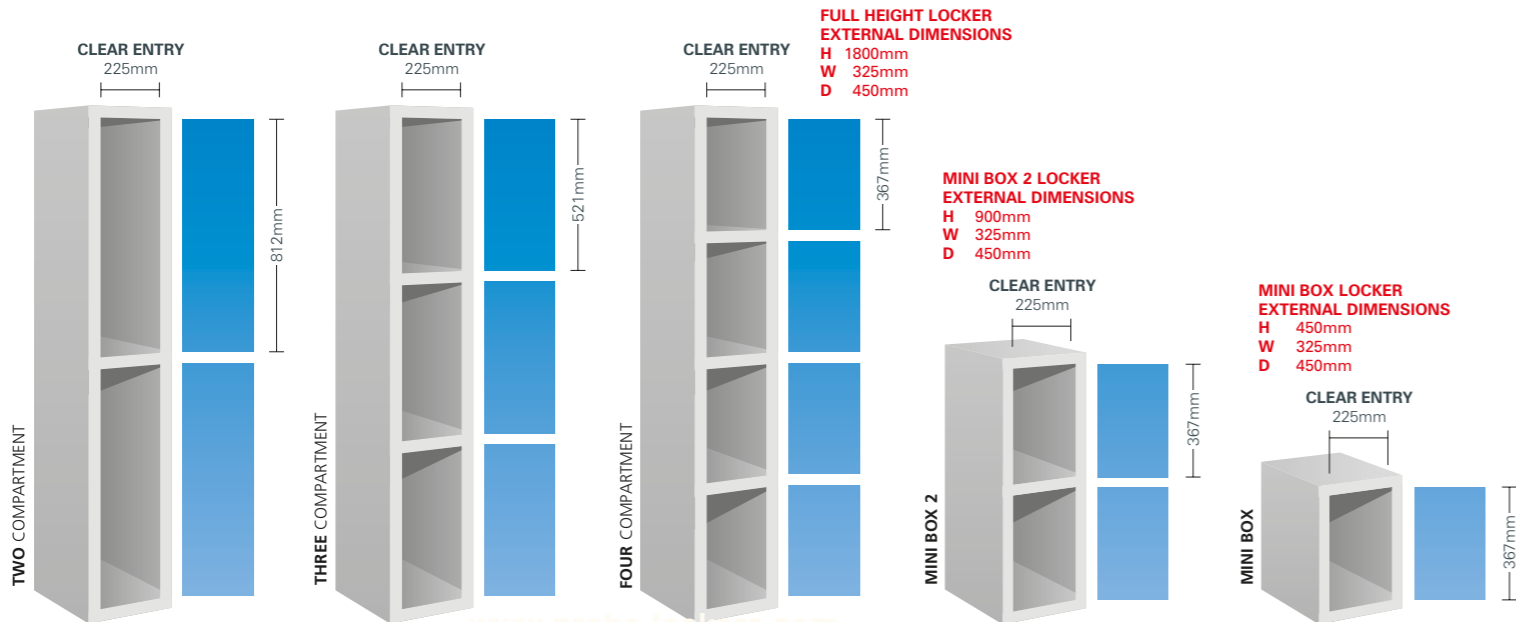

www.probe-lockers.com

